

# Seuic

## X3G

### Universal fixed code reader Make data collection more efficient

X3G is a plug-and-play universal fixed barcode reader designed for semi-automated data acquisition. The design concept of the high-sensitivity scanning head makes automatic acquisition more sensitive, can prevent slow reading speed, missed scanning, and can easily read many types of barcodes and QR codes such as electronic components, product packaging, paper tickets, mobile phone screens, etc.



#### ■ Sensitive induction, immediate release and sweep

With a highly sensitive scan engine, automatic recognition is faster



#### ■ Free your hands to double the efficiency

Change the operation mode of holding the barcode in one hand and the scanner in the other hand to the barcode can be scanned when it is placed, simplifying the operation and improving efficiency

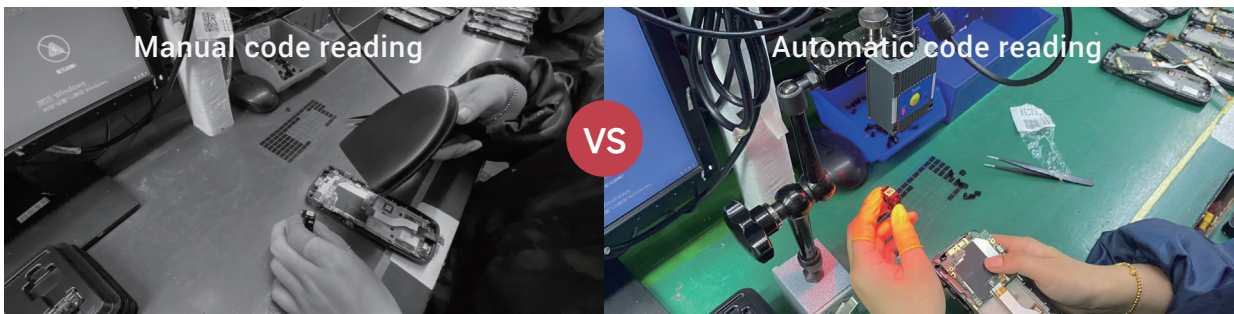

#### ■ Compact appearance Easy to embed

Ultra-small alloy body, easy to embed in self-service terminals

#### ■ Application



Electronics assembly lines



Packaging line



Test bench integration



Self-service terminal integration

## X3G technical specifications

image sensors	CMOS sensor with global shutter 1280*800		
Lighting sources	High brightness red LED		
Sights	Red linear sight		
Framerate	Up to 60 fps/s		
Readable barcode types	1D: All standard 1D barcodes		
	2D: DataMatrix (ECC200) 、QR code 、Micro QR、PDF417、MicroPDF417、Maxicode、Aztec and so on		
Reading direction	Supports omnidirectional reading of barcodes in any		
Recognition	1D code: 3.3mil		
	2D code: 5.0mil		
Identification distance		HD High Density Edition	SR Standard Edition
	3.3mil Code 39	40mm ~ 80mm	/
	10mil Code 39	50mm ~ 150mm	50mm ~ 200mm
	10mil Datamatrix	30mm ~ 130mm	35mm ~ 250mm
	ENA-13 100%	30mm ~ 165mm	30mm ~ 300mm
Field of view angle	Level 46° (H) , Vertical 29° (V)		
Code reading mode	Button Mode、 Automatic sensing、 Sequential mode、 Serial commands		
Print Contrast	≥30%		
Communication interface	USB、 RS-232		
Size	40mm x 50.3mm x 23mm (No cable included)		
Weight	Approx. 34g (without cable)		
Operating temperature	0°C to 50°C		
Storage temperature	-20°C to 70°C		
Humidity	5% to 95% RH Condensation-free condition		
Level of protection	IP54		
Shell material	Aluminium+ABS engineering plastics		
Power supplies/Electricity consumption	DC 5V±5% ; 300 mA ±5% (Typical value) , 450 mA ±5% (Maximum value)		

## Installation dimensions

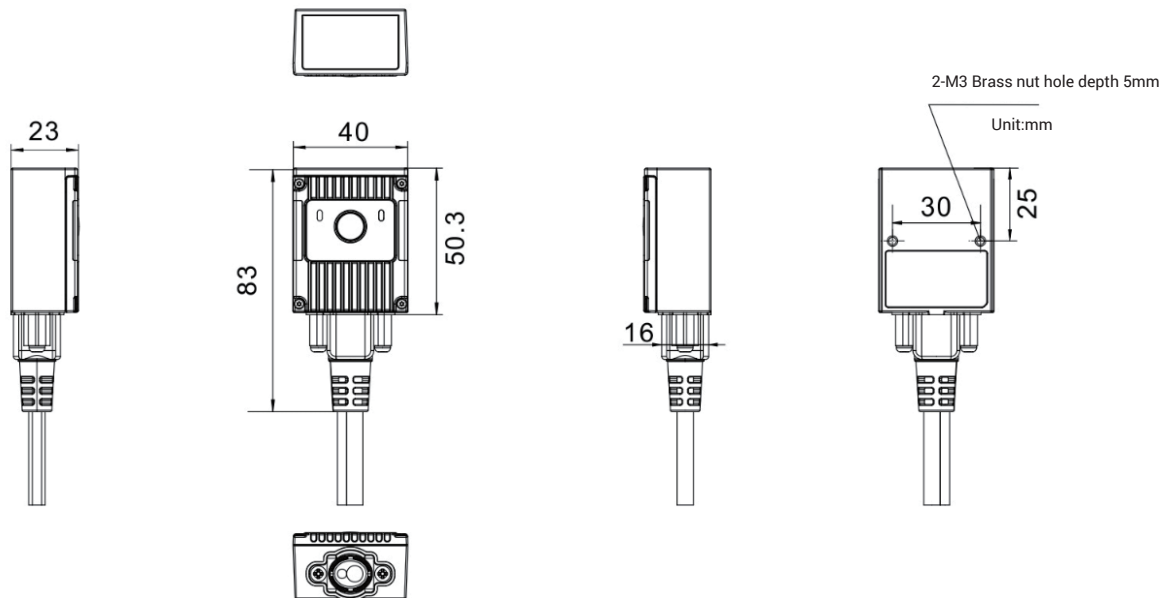

Official Website:  
www.seuic.us  
en.seuic.com



Service Mail:  
inquiry@seuic.us  
marketing@seuic.com

